

UltraCruiser Updates 11/2/04

Page #0

1. Changed quantity of stainless steel rivets to 80.
2. Added 50 AN470AD4-11 Rivets.
3. Added 50 1682-0414 Avex rivets.
4. Changed landing gear strut plate blank size from 4' x 1' x .188 to 1' x 1' x .188.
5. Added a note that if the builder is going to construct the formed ribs they need to order (2) additional sheets of .016 6061T6 material.
6. Changed the (2) AN4-25A bolts to AN4-27A.
7. Added (14) 2600LW retaining clips to material list.
8. Changed the quantity of 3/4 x .035 tubing from (3) 12' pieces to (2) 12' pieces.
9. Added (1) piece of 1" x .058 wall tubing 6" long to mat'l list.
10. Added (25) aluminum rivet washers with a .125 I.D. for mounting the windshield.

Page #1

1. Changed the type of rivets to attach the seat belt doublers from type 1 to type 2.
2. Added the bottom rails 3/4" x 3/4" x 1/16" to the side view of the fuselage for duplication. (They are shown on page 8.)
3. Changed suggestion for attaching the seat belts. It seems to work well to attach the lap belts to the bottom rails. (See diagram below.)

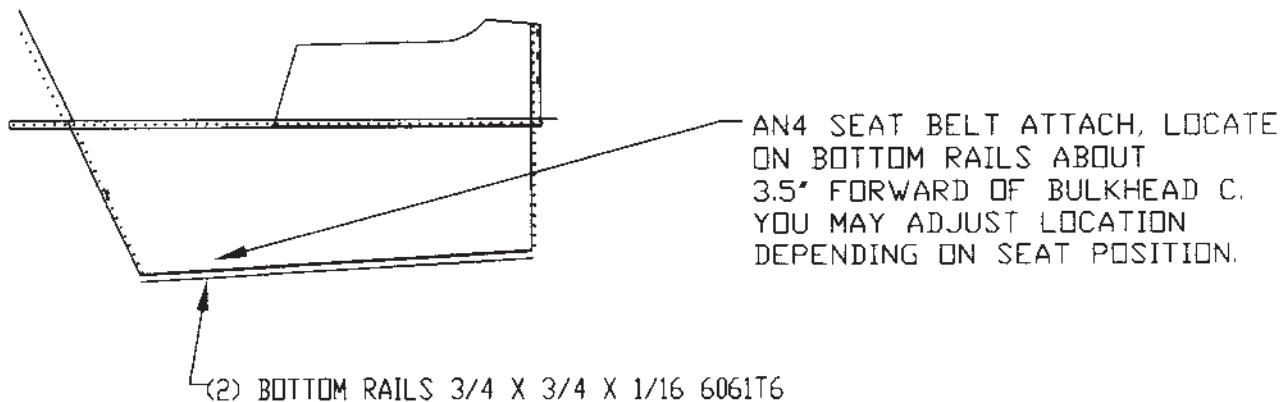

NOTE: SMALL DILITE BUSHINGS (FB46-02) CAN BE USED TO BUSH THE SEAT BELT TIE DOWN BRACKETS.